

Knife gate valve WB11

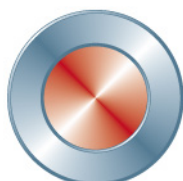
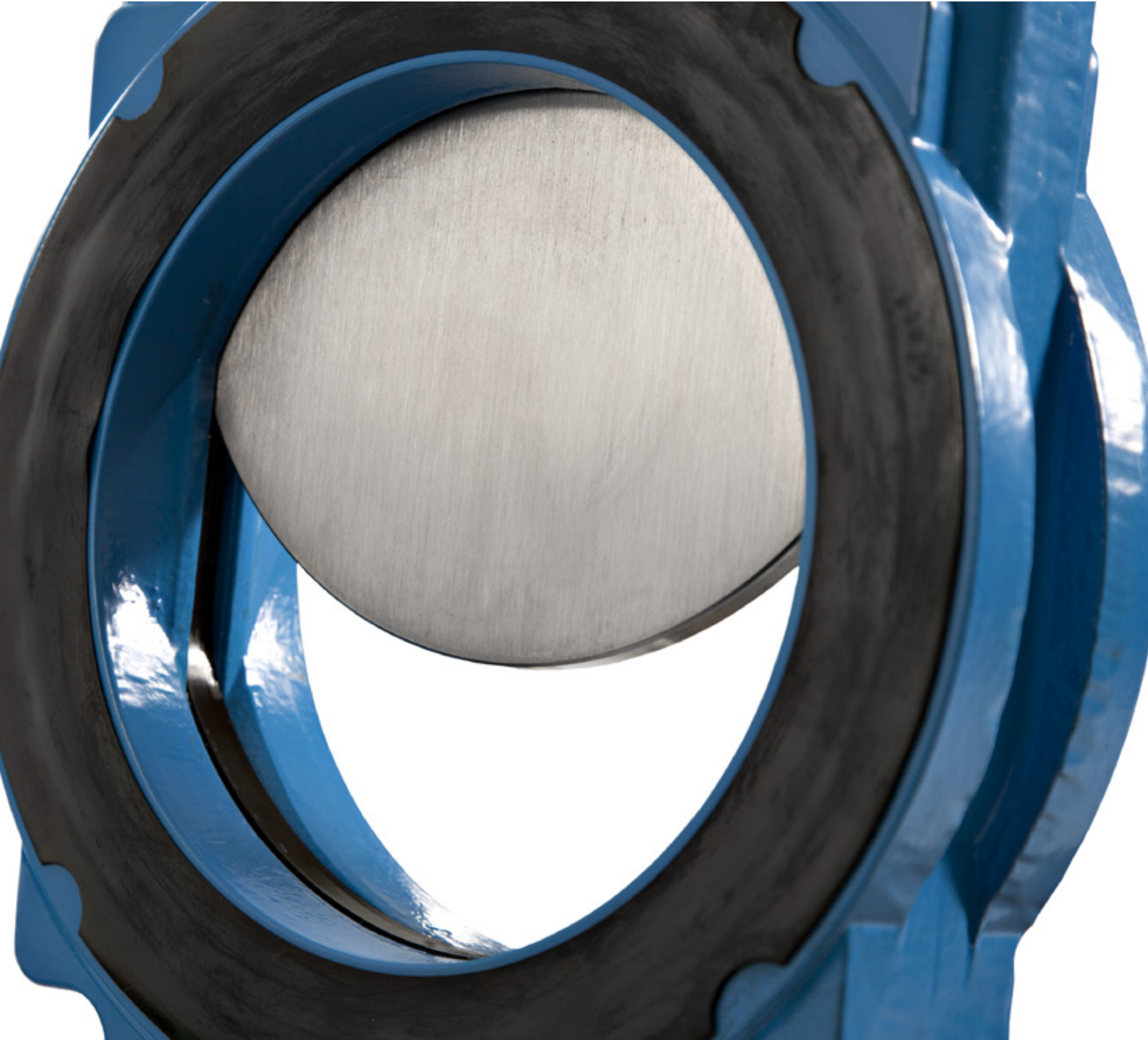

Stafsjö
SINCE 1666

Data is only for informational purpose. All specifications are subject to change without notice.

Knife gate valve WB11

Stafsjö's knife gate valve WB11 is bi-directional tight and has a cavity free full bore with superior flow characteristics. Integrated flange gaskets makes it easy to install. The valve is suitable for fluids, sludge and liquids with solids in suspensions such as water, waste water and bio mass.

The WB11 has a robust coated valve body in nodular iron. It is equipped with a gate in stainless steel, which has a polished edge in order to minimize friction and to lower required operation force. The valve is supplied with a steel reinforced sealing profile in Nitrile or EPDM. The gland box is equipped with Stafsjö's box packing TwinPack™ to secure that no media reaches the surrounding environment. The valve is modular designed and it can easily be supplied with different types of actuators and accessories.

The WB11 valve is designed, manufactured, inspected and tested according to pressure equipment directive 2014/68/EU category I and II module A2. The valve is CE marked when it is applicable.

Other WB versions are the semi lugged WB available from DN 350 up to DN 1600 and the fully lugged WB14 available up to DN 600. For square flange connection we are able to supply WB11k with additional tapped holes for this or WB12 which has a square fully flanged valve body.

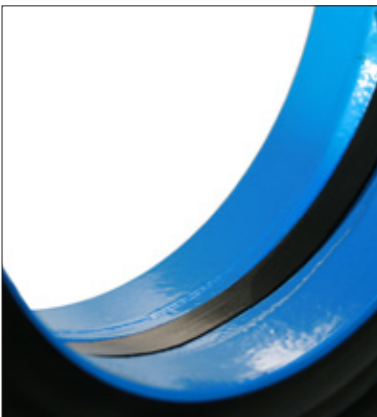

Superior flow characteristics

A cavity free full bore with a seat in level with the bore ensure minimal pressure drop and prevent any build up of media during operation.



Bi-directional zero leakage shut-off

The highly polished gate can easily cut through the media. Casted gate supports in the bore and a steel reinforced resilient perimeter seat provides a tight shut-off in both directions.



A first-rate sealing

A gland box supplied with three layers of our TwinPack™, which is specially developed and made for Stafsjö's valves, secures that no media reaches the surrounding environment.

Design data

Sizes	Flange drilling	Face-to-face-dimension	ATEX design	Corrosion protection
DN 50 - DN 300	EN 1092 PN 10 ASME/ANSI B 16.5 Class 150 Addition: WB11k	EN558-1 series 20 ISO 5752 series 20	On request directive 2014/34/EU Group II category: 3 G/D (zone 2 or 22) 2 G/D (zone 1 or 21)	Non-corrosive resistant materials are coated in colour RAL5015 acc. to Stafsjö's standard, which fulfill the requirements in EN ISO 12944 class C3.

Other sizes, ATEX zones and corrosion protection on request.

Leakage rate	Pressure tests
EN 12266-1:2009 rate A: No visually detectable leakage is allowed for duration of the test	Pressure tests are performed with water at 20° C according to EN 12266-1:2009. Pressure shell test: 1,5 times maximum allowable working pressure for open valve. Pressure seat tightness test: 1,1 times maximum allowable differential pressure for closed valve.
Maximum working pressure body at 20°C	Maximum differential pressure at 20°C
DN	bar
50 - 300	10

Basic equipment

A. Valve Body			
Material	Code	Type	Maximum temperature °C
Nodular iron	L	EN-JS1050 (GGG50)	200
B. Gate			
Material	Type		
Stainless steel	EN 1.4301 (AISI 304)		
<i>Option:</i>			
Stainless steel	EN 1.4404 (AISI 316L)		
C. Seat			
Material	Code	Maximum temperature °C	
EPDM	E	120	
Nitrile	N	100	
D. Box packing			
Material	Code	Maximum temperature °C	
TwinPack™	TY	260	

Actuators

Manual	Code	Automatic	Code
Hand wheel ¹⁾	HW	Pneumatic cylinder	EC
Hand lever ²⁾³⁾	HL	Electric motor	EM
Chain wheel ²⁾	CW	Hydraulic cylinder ²⁾	MH
Ratchet wrench ²⁾	RW		
Bevel gear ²⁾	BG		

¹⁾ For recommended size, see page 5, column E.

²⁾ For recommended size, see separate datasheet.

³⁾ Pressures according to design data are not valid for valve equipped with hand lever. Maximum working and differential pressure at 20°C for DN 50 - 200 is 4 bar.

Double-acting pneumatic cylinder			Electric motor (AUMA multi-turn)		
DN valve	EC type	Force at 5 bar(kN)	DN valve	AUMA type	Attachment
50 - 125	EC 100	3,5	50 - 150	SA 07.2	F10/A
150	EC 125	5,5	200 - 250	SA 07.6	F10/A
200 - 300	EC 160	9,0	300	SA 10.2	F10/A

The table above gives recommended cylinder sizes at normal option with 5 bar air pressure. For other operating conditions, please contact Stafsjö or your local representative for advice.

Electric motors are mounted according to standard ISO 5210. The table above gives recommended motor sizes at normal operation. For other operating conditions, please contact Stafsjö or your local representative for advice.

The actuators are described in separate data sheets. For advice and information on other actuators or on ATEX-classified ones, please contact Stafsjö or your local representative.

Specify the Stafsjö valve

Stafsjö's valves are modular designed and they can easily be customized with gate, sealing profile and box packings according to media and requirements, as well for actuators and accessories. Below are examples of how you can specify your Stafsjö valve. Further information is available on www.stafsjo.com.

WB11-L-200-E-TY-HW-PN10-1.4404

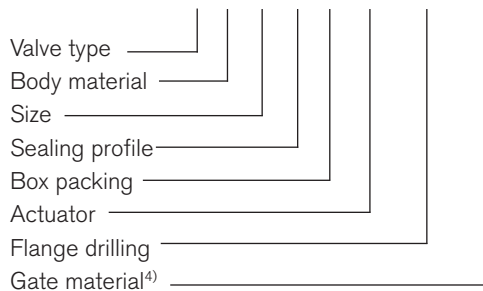

WB11-L-200-N-TY-EC160-PN10-ILS-SV

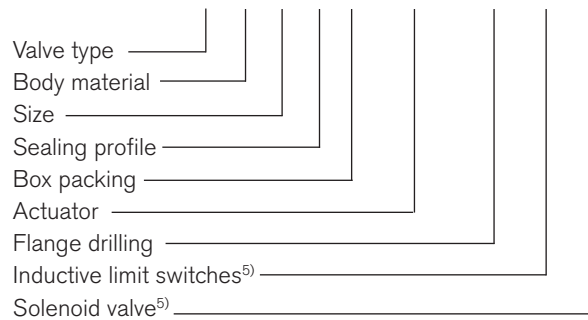

⁴⁾ Alloy specified if it differ from standard.

⁵⁾ All electronics must be specified in detail.

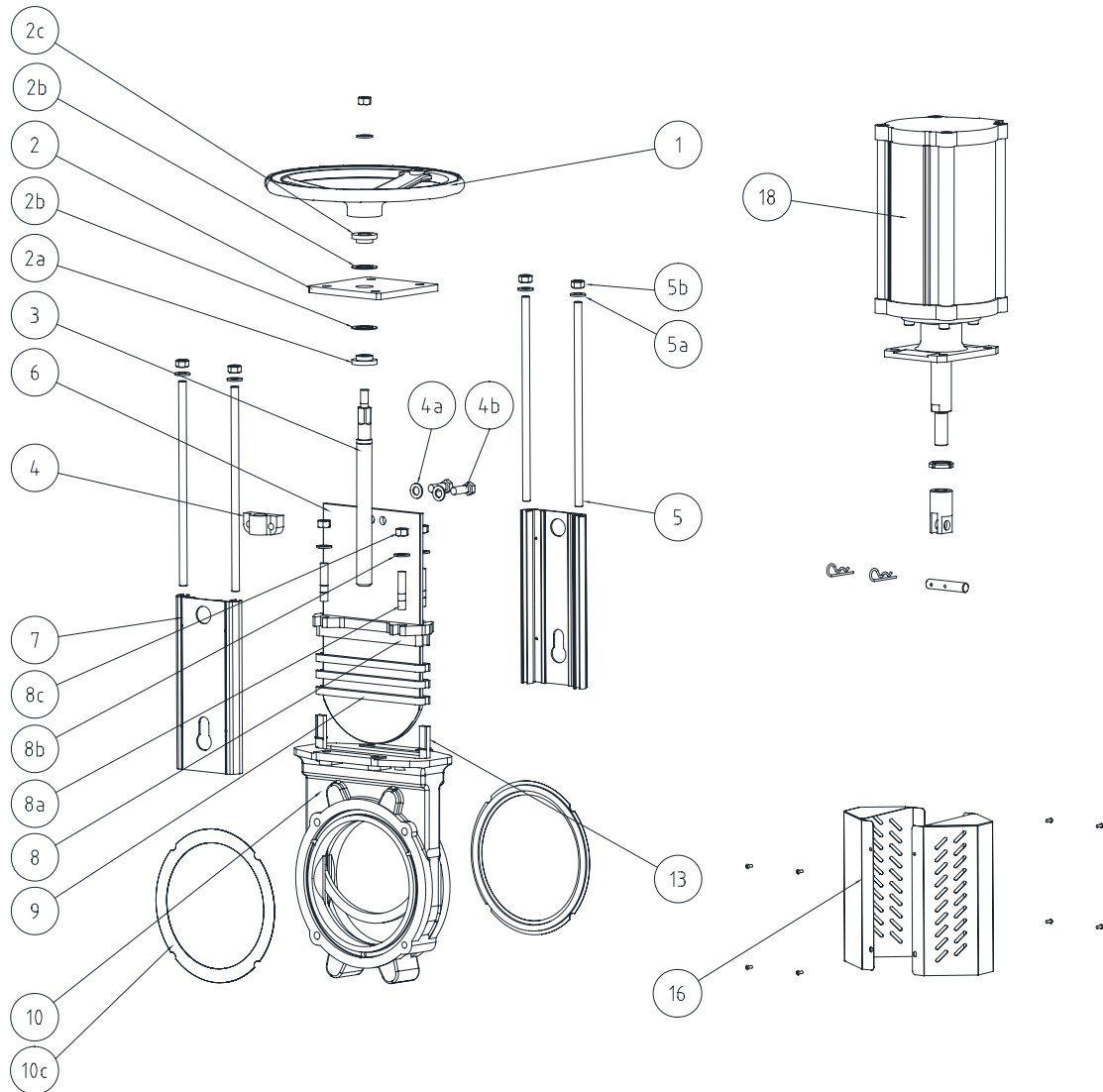

Part list

Pos	Part	Material (Name)
1	Hand wheel	Coated cast iron Ø 200 - Ø 315 (EN-JL1040 (GG25))
2	Yoke	Coated steel (EN 1.0038)
2a	Bearing	Brass (CuZn39Pb3)
2b	Slide washer	POM
2c	Bearing	Brass (CuZn39Pb3)
3	Stem	Stainless steel (EN 1.4016)
4	Stem nut	Brass (CuZn39Pb3)
4a	Washer	Stainless steel (A2)
4b	Bolt	Stainless steel (A2)
5	Tie rod	Stainless steel (EN 1.4301)
5a	Washer	Stainless steel (A2)
5b	Nut	Stainless steel (A2)
6	Gate	See equipment B
7	Beam	Aluminium (EN AW-6063-T6)

Pos	Part	Material (Name)
8	Gland	Coated carbon steel (ASTM A216 (WCB)) or coated nodular iron (EN-JS1050 (GGG50))
8a	Stud bolt	Stainless steel (A2)
8b	Washer	Stainless steel (A2)
8c	Nut	Stainless steel (A2)
9 ⁶⁾	Box packing	See equipment D
9a ⁶⁾	Box bottom scraper	≥ DN 200 UHMWPE
10	Valve Body	See equipment A
10c ⁶⁾	Flange sealing	Nitrile
13 ⁶⁾	Sealing profile	See equipment C
16	Gate Guard not for HW	Coated steel (EN 1.0038)
18	Cylinder	See datasheet

⁶⁾Recommended spare parts

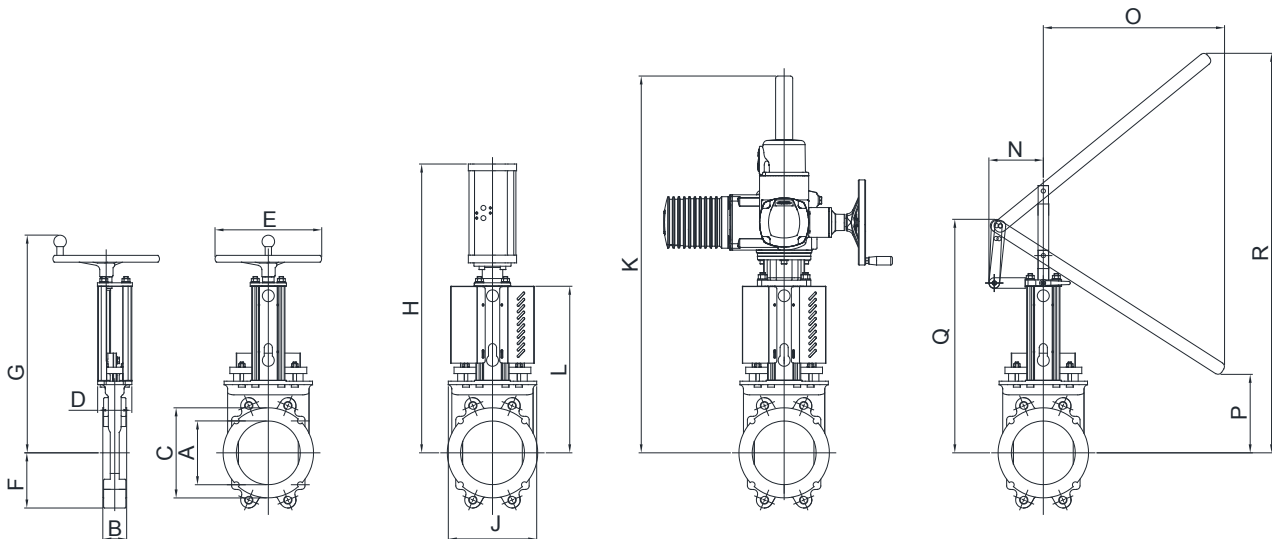

Main dimensions

Dimensions (mm)																	
DN	A	B	C	D	E	F	G	H	J	K	L	N	O	P	Q	R	Weight ¹⁾
50	50	43	90	86	200	59	358	465	117	629	227	149	499	128	381	419	6,5
65	65	46	105	86	200	66	382	490	131	654	252	147	492	153	407	511	8,0
80	80	46	120	86	200	89	395	513	130	677	275	144	479	176	429	598	10,0
100	100	52	144	86	200	101	430	548	151	712	310	146	635	17	472	653	12,5
125	125	56	169	86	250	115	470	638	177	752	350	137	591	57	512	846	16,5
150	150	56	192	86	250	130	514	727	201	794	392	129	554	99	554	1039	19,5
200	200	60	256	151	315	155	622	866	265	818	483	217	633	247	716	1117	32,5
250	250	68	307	151	315	193	718	1050	335	914	579	-	-	-	-	-	48,5
300	300	78	354	151	315	228	822	1146	372	1059	675	-	-	-	-	-	66,0

¹⁾ Weight in kg for valve equipped with hand wheel.

Main dimensions are only for information. Contact Stafsjö for certified drawings.

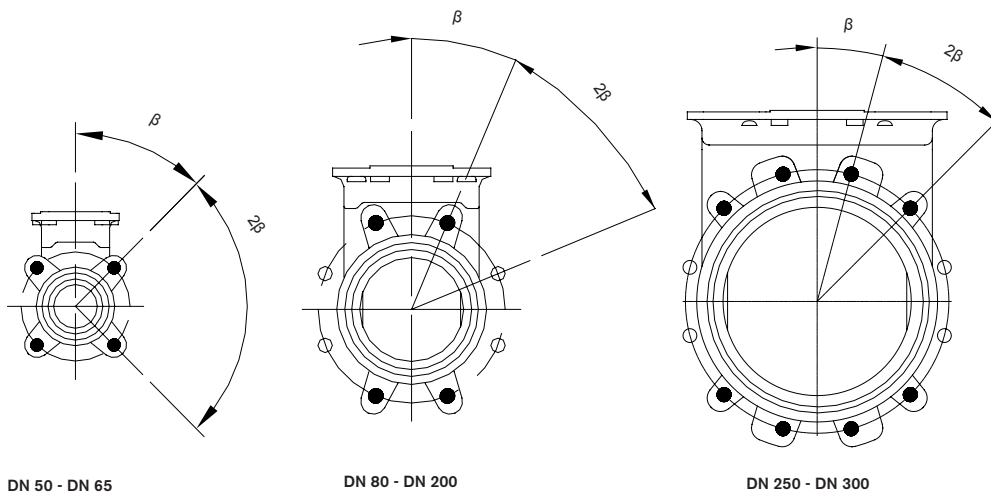

Flange drilling according to EN 1092 PN10

Flange drilling information (mm)									
DN	50	65	80	100	125	150	200	250	300
Outside flange diameter	165	185	200	220	250	285	340	395	445
Bolt circle diameter	125	145	160	180	210	240	295	350	400
Number of throughgoing bolts (○)	-	-	4	4	4	4	4	4	4
Number of tapped hole/side (●)	4	4	4	4	4	4	4	8	8
Bolt size	M16	M16	M16	M16	M16	M20	M20	M20	M20
β°	45	45	22,5	22,5	22,5	22,5	22,5	15	15
Screw lengths ⁹⁾	12	12	11	15	15	15	16	20	20

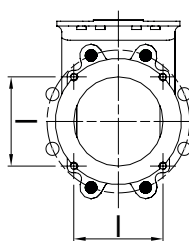

DN 150 - DN 200

Flange drilling WB11k⁹⁾

EN 1092 PN10 and additional tapped holes for WB11k (mm)		
DN	150	200
Number of extra tapped holes on each side	4	4
Bolt size	M12	M12
l (mm)	150	180
Screw lengths ⁹⁾ (mm)	16	18

○ Throughgoing holes

● Tapped holes

⁸⁾Add the values with the thickness of the pipe flanges and the washers.

⁹⁾ Pressures according to design data are not valid for valves with the special square WB11k drilling. Maximum working and differential pressure at 20°C for DN 150 - DN 200 is 4 bar.

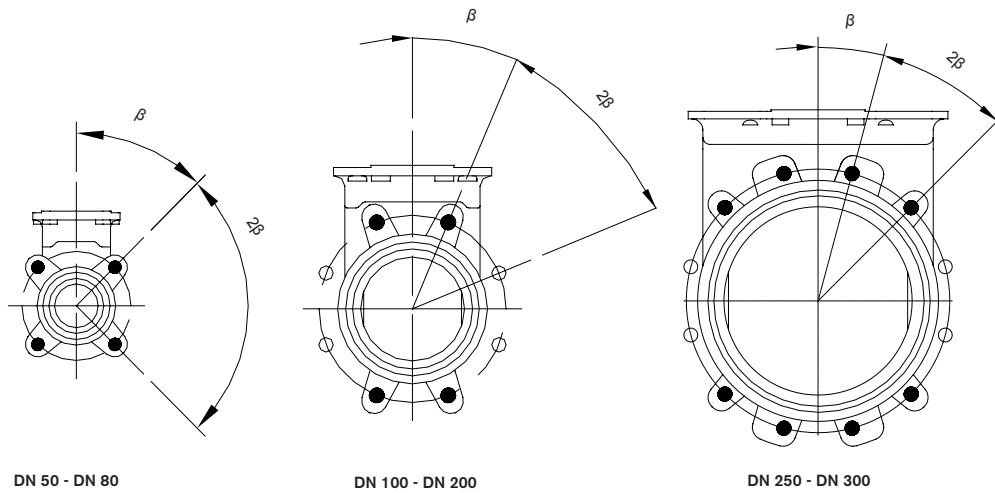

Flange drilling according to ASME/ANSI B 16.5 Class 150

Flange drilling information (mm)									
DN	50	65	80	100	125	150	200	250	300
Outside flange diameter	152,4	177,8	190,5	228,6	254	279,4	342,9	406,4	482,6
Bolt circle diameter (mm)	120,6	139,7	152,4	190,5	215,9	241,3	298,4	361,9	431,8
Number of throughgoing bolts (○)	-	-	-	4	4	4	4	4	4
Number of tapped hole/side (●)	4	4	4	4	4	4	4	8	8
Bolt size (UNC)	5/8-11	5/8-11	5/8-11	5/8-11	3/4-10	3/4-10	3/4-10	7/8-9	7/8-9
β°	45	45	45	22,5	22,5	22,5	22,5	15	15
Screw lengths ⁸⁾	12	12	11	15	15	15	16	20	20

○ Throughgoing holes

● Tapped holes

⁸⁾Add the values with the thickness of the pipe flanges and the washers.

Further information is available on www.stafsjo.com

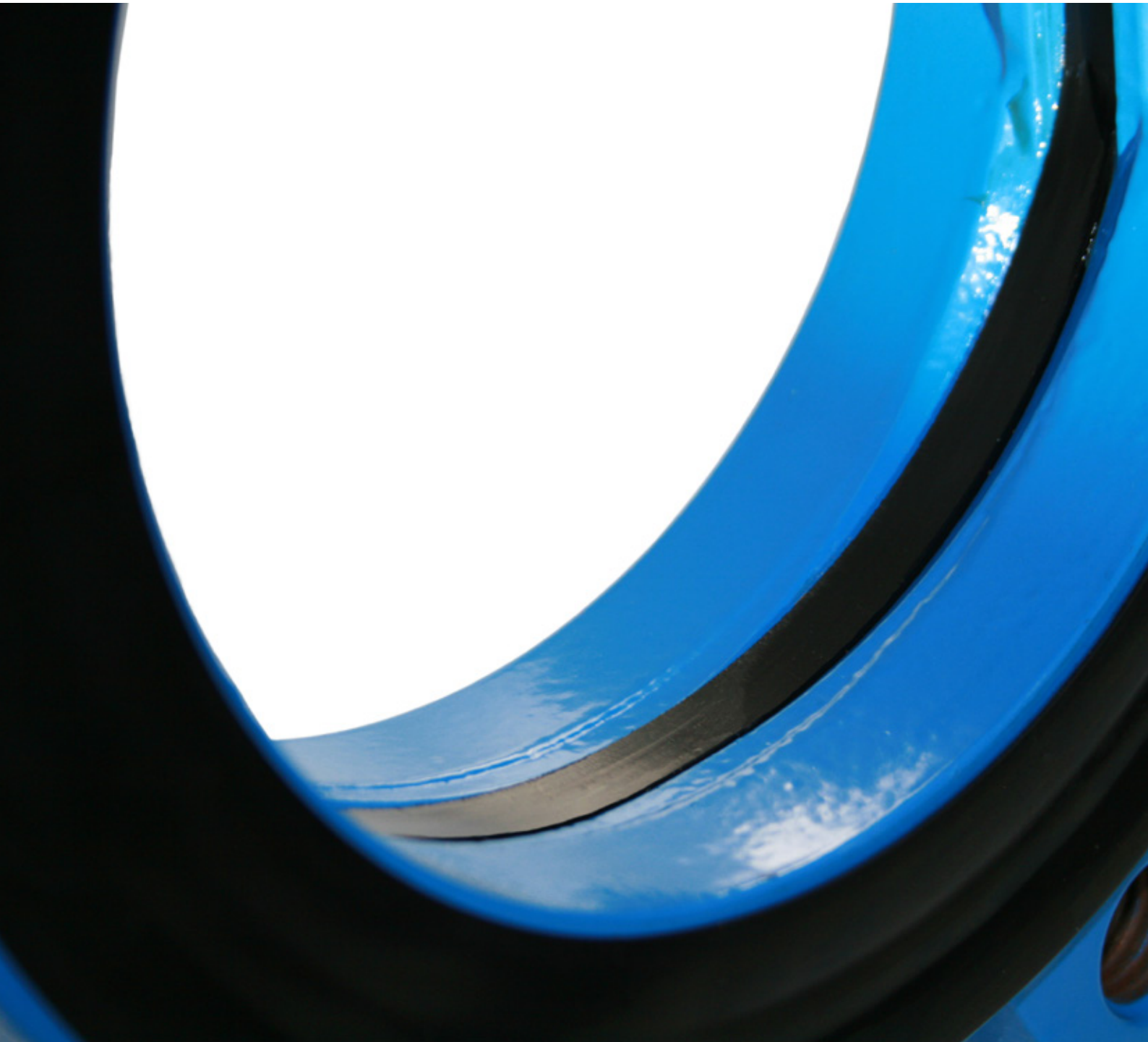

Globally active. Locally represented.

AFRICA South Africa: Valve & Automation (Pty) Ltd, **ASIA** China: Ebro Armaturen (Beijing) co., Ltd, India: Ebro Armaturen India Pvt. Ltd, Indonesia: Contromatic Prima Mandiri PT, Japan: SKC Co. Ltd, Malaysia: Precision Control SdnBnd, Philippines: Ebro Armaturen (Philippines) Inc., South Korea: Sherpa Automation, Thailand: Ebro Valves (Trading) Co. Ltd., Vietnam: Ebro Valves (Thailand) Co., Ltd, **AUSTRALIA with OCEANIA** Australia: Ebro Armaturen Pacific Pty Ltd, New Zealand: H.J. Asmuss & Co. Ltd **EUROPE** Austria: Ebro Armaturen GmbH, Belgium: V.C.T. - Valve & Connector Technology n.v., Denmark: Valtor Industri A/S, Finland: Tecalemit Flow Oy, France: Ebro Armaturen, Germany: Ebro Armaturen Gebr. Bröer GmbH, Great Britain: Ebro Valves Ltd, Hungary: Ebro Armaturen Kft, Ireland: ESI Technologies Ltd, Iceland: Hédinn HF, Italy: Ebro Valvole srl, The Netherlands: Ebro Valves B.V., Norway: Bagges AS, Poland: Ebro Armaturen GmbH, Portugal: AxFlow Comércio de Aquipamentos Lda, Russia: LesBumMash Ltd, Roitech and OOO Hawle Sevkom, Spain: Ebro Armaturen España, S.L., Switzerland: Ebro Armaturen Est. & Co. KG, Sweden: Stafsjö Valves AB and Ahlsell Sverige AB, Turkey: Ebro Armaturen Otomasyon Sistemleri San ve Tic Ltd. Sti, Ukraine: Ebro Armaturen GmbH Representative office Kiev **NORTH AMERICA** Canada: Armour Valve Ltd, USA: Ebro Armaturen USA Inc. **SOUTH AMERICA** Argentina: Esco Argentina S.A., Brazil: ELAN Equipamentos Industriais Ltda, Chile: Ebro Stafsjö Valves Chile Ltd For other countries, please contact us directly.

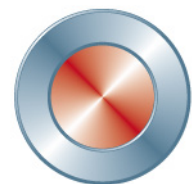

Stafsjö
SINCE 1666