

Stafsjö®
SINCE 1666

Knife gate valve HG

High performance through-going knife gate valve

Size range:

2" - 48" (DN 50 - DN 1200)

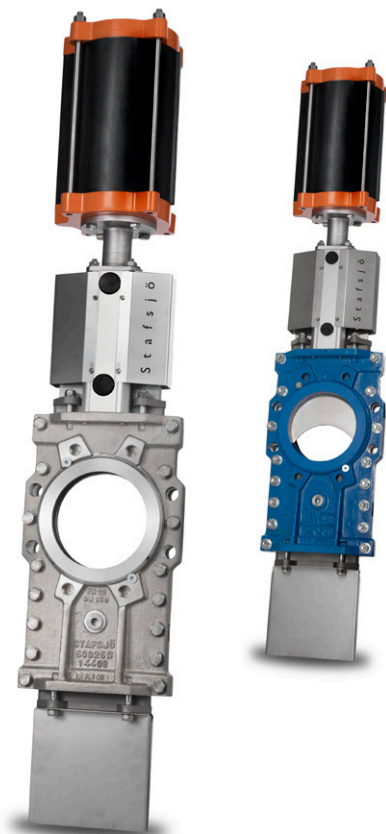
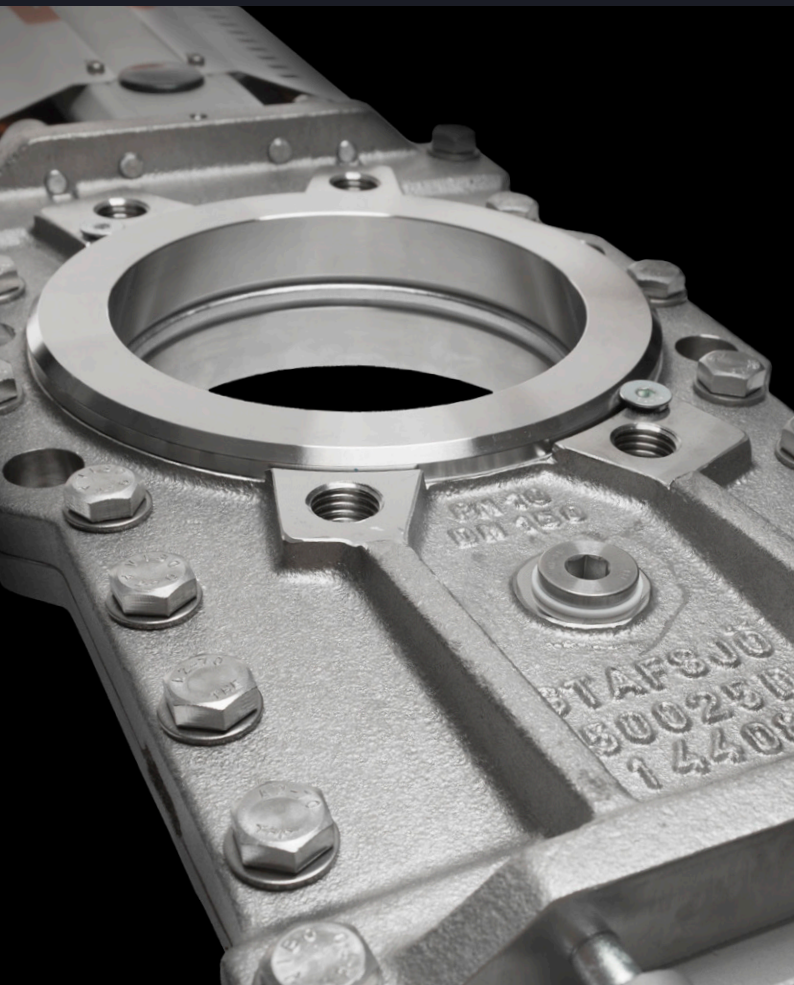

About HG

Stafsjö's HG is a through-going high performance knife gate valve with superior flow characteristics, offering reliable bi-directional zero leakage shut-off on highly concentrated media and static media columns.

The HG knife gate valve is modular designed and can easily be customized in materials, with actuators and related automation accessories to different process conditions. It can operate on different media such as pulp stock up to 18% consistency, slurry, liquor, ash and granulate. It is also widely used in junc traps, mostly as inlet valve with our RKO as discharge valve. The HG has a rigid two-piece precision machined valve body with a high strength top works that provide an essential and precise gate alignment. As standard it is available with a valve body in stainless steel or nodular iron, but it can also be supplied in a range of high alloy materials such as Duplex and 254 SMO equivalent material.

The HG valve is one out of five of Staffsjö's through-going knife gate valve models. The HP is a high pressure version of HG while the HL is a compact version. HPT is a high pressure version entirely made in Titanium and the HX is an extreme high pressure version.

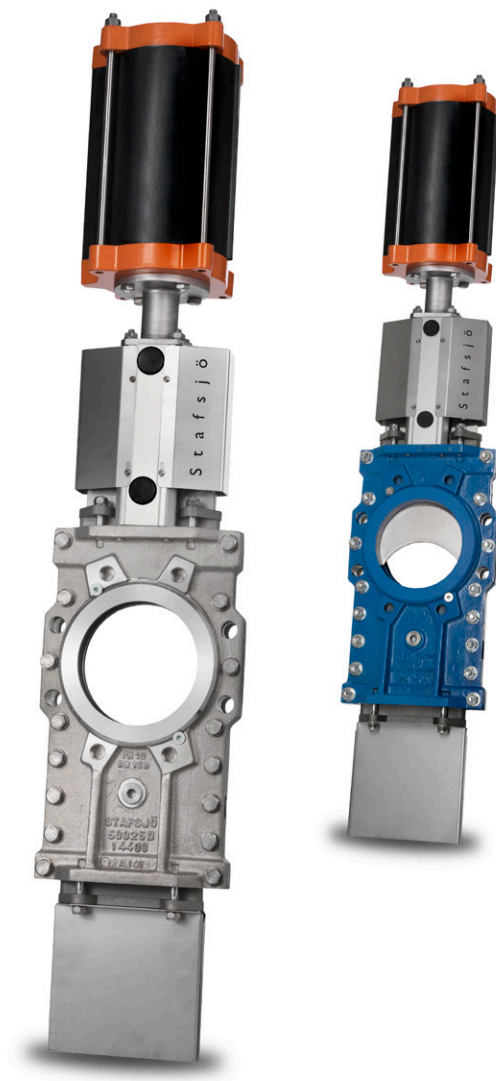

Full bore with outstanding flow characteristics

When the HG knife gate valve is in open position, it offers an unobstructed flow path where no media can collect. The PTFE seats (1) are protected by the gate (2) and retainer rings (3) and the internal back-up o-rings (4) keep the seats constantly pressurized against the gate. Polyurethane retainers/seats is an option for abrasive processes while the metal only is an extreme high temperature option.

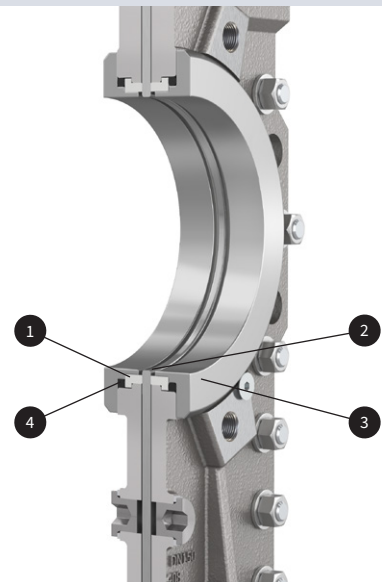

Reliable through-going and bi-directional zero leakage shut-off

The gate is guided throughout the entire stroke and operates smoothly through difficult and highly concentrated media. The retainer ring system (5) on both side of the gate provide a tight seal independent of pressure direction. The gland box sealing system with three layers of Stafsjö's TwinPack (6) ensures that no media reaches surrounding environment. Extra scrapers or double gland can be used for the most demanding services.

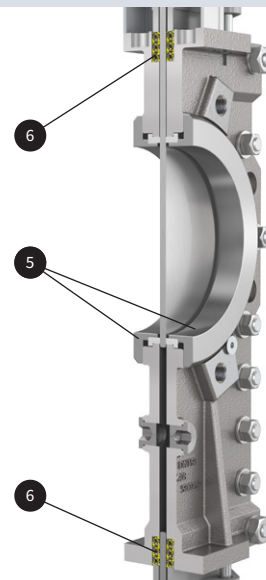

Quick and easy maintenance

The retainer rings (7) hold the seats (8) and the back-up o-rings (9) in exact correct position as the gate strokes. They are mechanically locked and can easily be removed for seat change. Both the retainer rings and seats are available in different materials which makes it easy to customize HG to different process conditions.

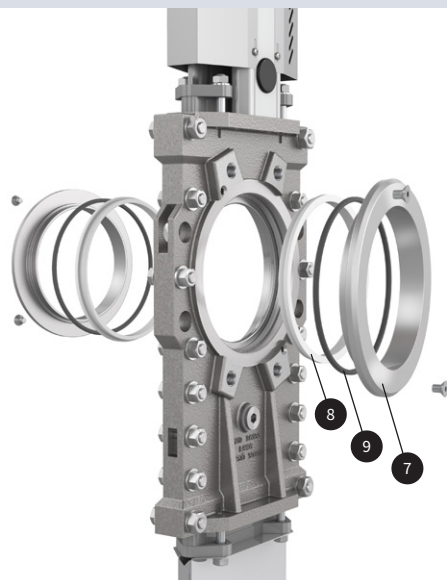

Pressure class

Max working pressure at 68 °F		Max differential pressure at 68 °F	
NPS	psi/bar	NPS	psi/bar
2" - 10"	150/10	2" - 10"	150/10
12" - 32"	90/6	12" - 32"	90/6
36" - 48"	60/4	36" - 48"	60/4

Configurations

Standard in stainless steel	Standard in nodular iron
<p>Sizes: 2" - 48"</p> <p>Valve body: Stainless steel EN 1.4408</p> <p>Retainer rings: Stainless steel EN 1.4408</p> <p>Gate: Stainless steel EN 1.4404, AISI 316L</p> <p>Box packing: TwinPack</p> <p>Top works: Stainless steel tie rods encapsulated in aluminum beams up to 40" and stainless steel beams on larger ones including stainless steel gate guards on automated valves</p>	<p>Sizes: 3" - 24"</p> <p>Valve body: Nodular iron EN 5.3105</p> <p>Retainer rings: Nodular iron EN 5.3105, EN-JS1050. 24": Stainless steel EN 1.4408</p> <p>Gate: Stainless steel EN 1.4404, AISI 316L</p> <p>Box packing: TwinPack</p> <p>Top works: Stainless steel tie rods encapsulated in aluminum beams including stainless steel gate guards on automated valve</p>

Options	
<p>Valve body¹⁾ Nodular iron EN 5.3105 Stainless steel EN 1.4408 Duplex stainless steel EN 1.4470 254 SMO stainless steel equivalent</p> <p>Retainer rings Nodular iron EN 5.3105, EN-JS1050 Stainless steel EN 1.4408 Duplex stainless steel EN 1.4470 254 SMO stainless steel or equivalent Polyurethane</p> <p>Gate material and surface treatments Stainless steel EN 1.4404, AISI 316L Duplex stainless steel EN 1.4462, S32205 254 SMO stainless steel or equivalent Hard chromed surface Extra polished surface (max Ra 0,8)</p> <p>Seats PTFE with o-ring in NBR, EPDM or FKM/FPM FDA/EC 1935/2004 approved PTFE Polyurethane Stainless steel with grafoil tape or o-rings in NBR, EPDM or FKM/FPM</p>	<p>Box packings TwinPack, WhitePack, Graphite or FDA/EC 1935/2004 approved PTFE Extra scrapers in UHMW-PE, PTFE or brass</p> <p>Top works Stainless steel tie rods encapsulated in aluminum beams Stainless steel pillars²⁾ or beams</p> <p>Actuators Bevel gear Chain wheel Hand wheel with non-rising stem Double-acting pneumatic cylinder Single-acting pneumatic cylinder Electric actuator Hydraulic actuator</p> <p>Flange drillings EN 1092 PN 10 EN 1092 PN 16 ASME/ANSI B16.5 and B16.47 Class 150, series A JIS B 2238 10K BS 10 Table D AS 2129 Table D and E on request</p> <p>Accessories See Stafsjö's accessory data sheet for further information.</p>

Design standards	
<p>Design, manufacturing, inspection and test According to pressure equipment directive 2014/68/EU category I and II module A2. The valves are CE marked when it is applicable.</p> <p>Stafsjö's valves are subject for pressure tests before delivery in opened and closed position with water at 68 °F according to EN 12266-1:2003 rate A. No visually detectable leakage is allowed for duration of the test. Rate A is not applicable on metal seated valves.</p> <p>On request Stafsjö can provide 2.2 test report and 3.1 inspection certificate according to EN 10204.</p> <p>Contact Stafsjö for further information on ATEX approved solutions.</p>	<p>Face-to-face dimensions Stafsjö manufacturing standard. Option in MSS-SP81.</p> <p>Corrosion protection Painted valve parts fulfill in applicable areas corrosion protection against environment according EN ISO 12944, corrosivity category C3. Other paint systems can be offered on request.</p> <p>Service temperature Information to determine minimum and maximum temperature for the knife gate valve is available on stafsjo.com/support/temperatures/.</p>

1) The valve body is as standard supplied with purge ports from 4": G1/2"

2) Standard on valves supplied with valve body in duplex or equivalent material to 254 SMO stainless steel.

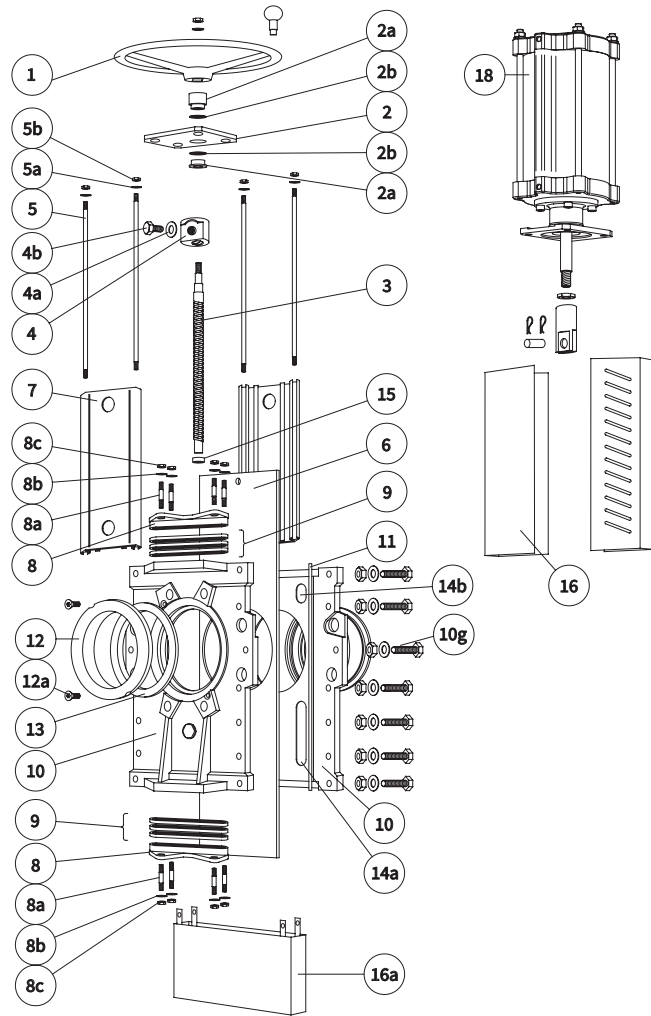

Part list

Pos.	Part	Material
1	Hand wheel	Coated cast iron Ø 8" - Ø 12": EN-JL1040, GG25, ≥ Ø 16" EN-JL1030, GG20
2	Yoke	Stainless steel EN 1.4301
2a	Bearing	Brass
2b	Slide washer	POM
3	Stem	Stainless steel EN 1.4016 alt. EN 1.4305
4	Stem nut	Brass
4a	Washer	Stainless steel A2
4b	Screw	Stainless steel A2
5	Tie rod	Stainless steel A2
5a	Washer	Stainless steel A2
5b	Nut	Stainless steel A2
6	Gate	See options on page 4
7	Beam	Anodized aluminum
8	Gland	HG-E: Stainless steel EN 1.4408 HG-L ≤ 12": Coated nodular iron EN 5.3105, EN-JS1050

Pos.	Part	Material
8a	Stud bolt	Stainless steel A2
8b	Washer	Stainless steel A2
8c	Nut	Stainless steel A2
9 ¹⁾	Box packing	See options on page 4
10	Valve body	See options on page 4
10g	Valve body boltings	HG-E: Stainless steel A2 HG-L: Zinc plated steel
11	Body gasket	2" - 6": Grafoil. 8" - 10": PTFE. ≥ 12" FPM/FKM
12	Retainer ring	See options on page 4
12a	Locking screw	Stainless steel A2
13 ¹⁾	Seat	See options on page 4
14a	Guiding pads	Only ≥ 10": PTFE
14b	Guiding pads	Only ≥ 10": PTFE
15	Bushing	Oil-bronze
16	Gate guards	Stainless steel EN 1.4301
18	Pneumatic cylinder	See separate data sheet

1) Recommended spare part

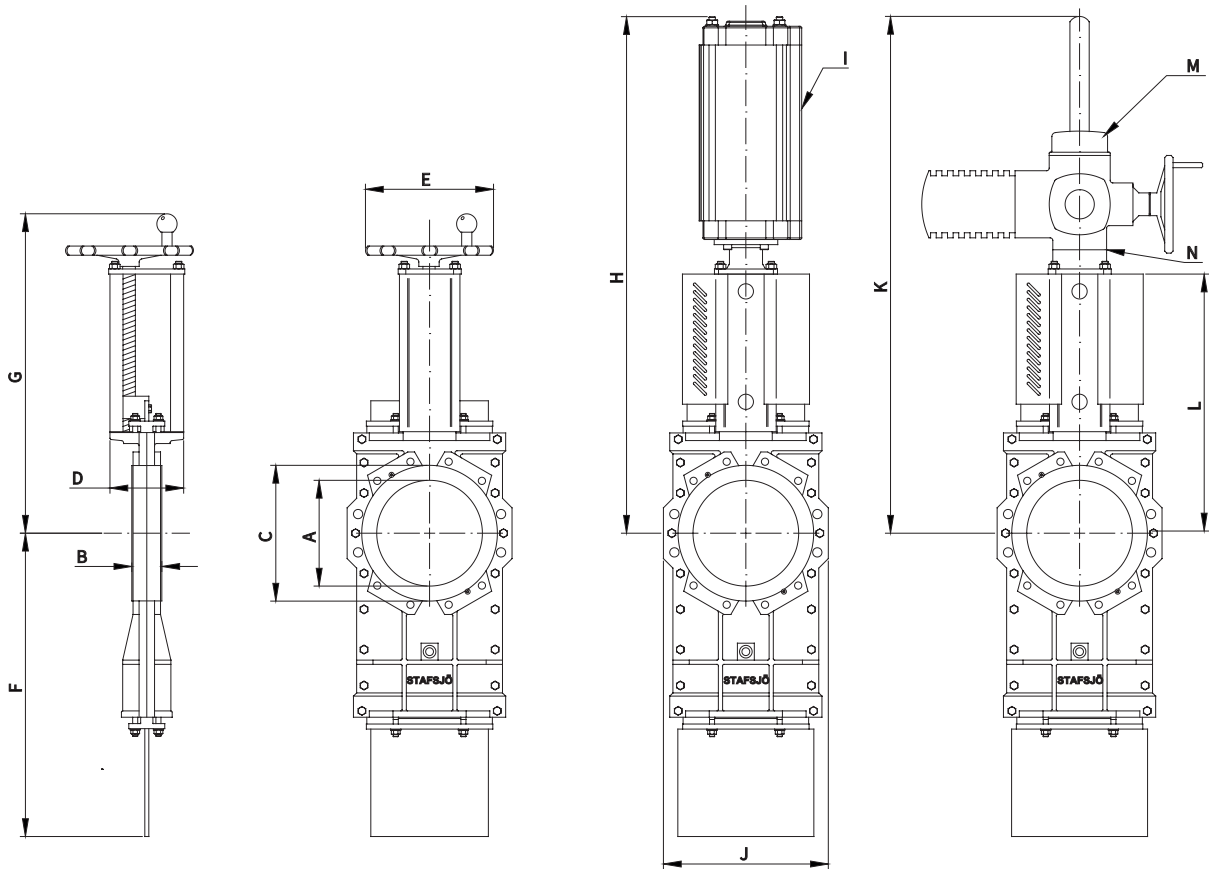

Main dimensions (inch)

NPS	A	B	C	D	E	F	G	H	I ¹⁾	J	K	L	M ²⁾	N ³⁾	lbs ⁴⁾
2	2,95	1,85	3,58	3,15	7,87	8,86	13,82	20,83	SC4.00	5,91	20,87	9,06	SA07.2	F10/A	26
3	3.11	2.01	4.92	2.76	7.87	11.22	15.94	21.61	SC4.00	7.09	29.29	10.83	SA07.2	F10/A	37
4	4.06	2.01	6.02	2.83	7.87	15.16	17.52	24.17	SC4.00	8.27	31.85	12.40	SA07.2	F10/A	49
5	5.04	2.20	7.05	3.15	9.84	16.69	19.09	29.65	SC6.30	9.45	34.41	13.98	SA07.2	F10/A	64
6	6.02	2.36	8.07	3.15	9.84	17.91	20.87	32.40	SC6.30	10.24	37.17	15.75	SA07.6	F10/A	75
8	7.95	2.36	10.63	5.91	12.40	23.62	25.94	38.35	SC6.30	12.99	42.13	20.47	SA07.6	F10/A	165
10	9.84	2.72	12.60	5.91	12.40	28.54	29.09	43.66	SC6.30	15.35	47.24	23.62	SA07.6	F10/A	220
12	11.89	3.07	14.76	7.09	15.75	34.06	35.16	52.44	SC8.00	17.91	55.91	28.35	SA10.2	F10/A	375
14	13.07	3.07	16.73	6.89	15.75	38.58	37.32	55.79	SC8.00	20.08	59.25	30.51	SA10.2	F10/A	441
16	14.96	3.50	18.90	8.27	20.47	42.13	40.67	62.40	SC8.00	22.44	64.96	34.37	SA10.2	F10/A	639
18	16.85	3.50	21.02	8.66	20.47	47.64	44.25	70.47	SC10.00	24.61	70.47	37.91	SA10.2	F10/A	904
20	18.50	4.49	22.83	12.60	25.00	55.59	51.14	78.35	SC10.00	27.17	79.53	44.80	SA14.2	F14/A	1477
24	21.26	4.80	26.73	13.78	25.00	61.14	52.60	83.19	SC12.60	31.50	84.06	46.26	SA14.2	F14/A	1808
28	26.18	5.04	31.50	12.60	-	74.45	-	96.77	SC12.60	39.17	98.62	54.92	SA14.6	F14/A	2866
30	27.95	5.28	33.82	12.60	-	77.56	-	102.13	PA14.00	39.82	105.91	58.27	SA14.6	F14/A	3530
32	29.92	5.04	35.43	12.60	-	83.94	-	107.20	SC12.60	42.13	109.06	61.42	SA14.6	F14/A	3748
36	34.65	5.04	39.72	12.20	-	97.13	-	118.82	SC12.60	45.98	119.13	68.50	SA14.6	F14/A	*
40	38.58	5.91	43.70	12.20	-	106.69	-	131.02	SC12.60	50.00	130.71	76.18	*	*	*
48	47.24	5.91	52.52	19.88	-	131.46	-	*	*	59.06	166.22	97.83	*	*	*

1) Recommended sizing of double-acting pneumatic cylinder type SC at normal operation with 5 bar air pressure. For other operating conditions, contact Stafsjö or your local representative for advice.

2) Recommended sizing of Auma SA electric motors at normal operation. For other operating conditions, contact Stafsjö or your local representative for advice.

3) Valve and Auma SA interface. The electric motors are mounted as standard with output drive type A (rising stem) according ISO 5210.

4) Weight in lbs for valve with hand wheel (HW)

* On request

Main dimensions are only for information. Contact Stafsjö for certified drawings.

Flange drilling according to EN 1092 PN 10

NPS	2	3	4	5	6	8	10	12	14	16
Bolt circle diameter (inch)	4.92	6.30	7.09	8.27	9.45	11.61	13.78	15.75	18.11	20.28
Number of throughgoing holes	0	4	4	4	4	4	4	4	4	4
Number of tapped holes/side	4	4	4	4	4	4	8	8	12	12
Bolt size	M16	M16	M16	M16	M20	M20	M20	M20	M20	M24
Bolt lengths ¹⁾ (inch)	0.51	0.51	0.51	0.59	0.59	0.63	0.71	0.79	0.79	0.98

NPS	18	20	24	28	30	32	36	40	48
Bolt circle diameter (inch)	22.24	24.41	28.54	33.07	35.43	37.40	41.34	45.67	54.33
Number of throughgoing holes	4	4	4	4	4	4	4	4	4
Number of tapped holes/side	16	16	16	20	20	20	24	24	28
Bolt size	M24	M24	M27	M27	M27	M30	M30	M33	M36
Bolt lengths ¹⁾ (inch)	0.98	1.06	1.10	1.10	1.18	1.22	1.22	1.50	1.57

Flange drilling according to EN 1092 PN 16

NPS	2	3	4	5	6	8	10	12	14	16
Bolt circle diameter (inch)	4.92	6.30	7.09	8.27	9.45	11.61	13.98	16.14	18.50	20.67
Number of throughgoing holes	0	4	4	4	4	4	4	4	4	4
Number of tapped holes/side	4	4	4	4	4	8	8	8	12	12
Bolt size	M16	M16	M16	M16	M20	M20	M24	M24	M24	M27
Bolt lengths ¹⁾ (inch)	0.51	0.51	0.51	0.59	0.59	0.63	0.71	0.79	0.79	0.98

NPS	18	20	24	28	30	32	36	40	48
Bolt circle diameter (inch)	23.03	25.59	-	33.07	-	37.40	41.34	46.06	57.72
Number of throughgoing holes	4	4	-	4	-	4	0	4	4
Number of tapped holes/side	16	16	-	20	-	20	28	24	28
Bolt size	M27	M30	-	M33	-	M36	M36	M39	M45
Bolt lengths ¹⁾ (inch)	0.98	1.06	-	1.10	-	1.22	1.22	1.50	1.57

Flange drilling according to ASME/ANSI B16.5 & B16.47 Class 150

NPS	2	3	4	5	6	8	10	12	14	16
Bolt circle diameter (inch)	4.75	6.00	7.50	8.50	9.50	11.75	14.25	17.00	18.75	21.25
Number of throughgoing holes	0	2	4	4	4	4	4	4	4	4
Number of tapped holes/side	4	2	4	4	4	4	8	8	8	12
Bolt size (UNC)	5/8"-11	5/8"-11	5/8"-11	3/4"-10	3/4"-10	3/4"-10	7/8"-9	7/8"-9	1"-8	1"-8
Bolt lengths ¹⁾ (inch)	0.51	0.51	0.51	0.59	0.59	0.63 ²⁾	0.71	0.79	0.79	0.98

NPS	18	20	24	28	30	32	36	40	48
Bolt circle diameter (inch)	22.75	25.00	29.50	34.00	36.00	38.50	42.75	47.25	56.00
Number of throughgoing holes	4	4	4	4	4	4	4	4	8
Number of tapped holes/side	12	16	16	24	24	24	28	32	36
Bolt size (UNC)	1 1/8"-7	1 1/8"-7	1 1/4"-7	1 1/4"-7	1 1/4"-7	1 1/2"-6	1 1/2"-6	1 1/2"-6	1 1/2"-6
Bolt lengths ¹⁾ (inch)	0.98	1.06	1.10	1.10	1.18	1.22	1.22	1.50	1.57

1) Add the values with the thickness of flanges, washers and gaskets.

2) The screws on one side has to be 0.39" longer for face-to-face according to MSS-SP81.

Flange drilling according to JIS B 2238 10K

NPS	2	3	4	5	6	8	10	12	14	16
Bolt circle diameter (inch)	4.72	5.91	6.89	8.27	9.45	11.42	13.98	15.75	17.52	20.08
Number of throughgoing holes	0	4	4	4	4	4	4	4	4	4
Number of tapped holes/side	4	4	4	4	4	8	8	12	12	12
Bolt size	M16	M16	M16	M20	M20	M20	M22	M22	M22	M24
Bolt lengths ¹⁾ (inch)	0.51	0.51	0.51	0.59	0.59	0.63	0.71	0.79	0.79	0.98

NPS	18	20	24	28	30	32	36	40	48
Bolt circle diameter (inch)	22.24	24.41	28.74	33.07	35.43	37.40	41.34	45.67	54.33
Number of throughgoing holes	4	4	8	4	4	4	4	4	4
Number of tapped holes/side	16	16	16	20	20	24	24	24	28
Bolt size	M24	M24	M30	M30	M30	M30	M30	M36	M36
Bolt lengths ¹⁾ (inch)	0.98	1.06	1.10	1.10	1.18	1.22	1.22	1.50	1.57

Flange drilling according to BS 10 Table D

NPS	2	3	4	5	6	8	10	12	14	16
Bolt circle diameter (inch)	-	5.75	7.00	8.25	9.25	11.50	14.00	16.00	18.50	20.50
Number of throughgoing holes	-	2	2	4	4	4	4	4	4	4
Number of tapped holes/side	-	2	2	4	4	4	4	8	8	8
Bolt size (UNC)	-	5/8"-11	5/8"-11	5/8"-11	5/8"-11	5/8"-11	3/4"-10	3/4"-10	7/8"-9	7/8"-9
Bolt lengths ¹⁾ (inch)	-	0.51	0.51	0.59	0.59	0.63	0.71	0.79	0.79	0.98

NPS	18	20	24	28	30	32	36	40	48
Bolt circle diameter (inch)	23.00	25.25	29.75	33.27	36.50	38.75	43.00	46.26	*
Number of throughgoing holes	4	4	4	4	4	4	4	4	*
Number of tapped holes/side	8	12	12	16	16	16	20	20	*
Bolt size (UNC)	7/8"-9	7/8"-9	1"-8	1"-8	1 1/8"-7	1 1/4"-7	1 1/4"-7	1 1/4"-7	*
Bolt lengths ¹⁾ (inch)	0.98	1.06	1.10	1.10	1.18	1.22	1.22	1.50	*

1) Add the values with the thickness of flanges, washers and gaskets.

* On request

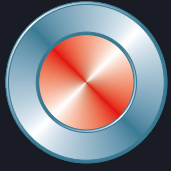

Stafsjö[®]
SINCE 1666

© Stafsjö 2025. Data is only for informational purpose. All specifications are subject to change without notice.

Stafsjö Valves AB
SE-618 95 Stavsjö, Sweden



+46 11 39 31 00 | sales@stafsjo.se | www.stafsjo.com

A Bröer Group Company